

SPECIFICATIONS

CARBURETOR JET SIZES	
Main jet	195
Slow jet	42

FUEL TANK CAPACITY	GALLONS	LITERS
Total (including reserve)	4.0	15.14
Reserve	0.6	2.27

CARBURETOR ADJUSTMENTS	
Engine fast idle speed (using enrichener circuit)	2000 RPM
Engine speed for setting ignition timing-world models	950-1050 RPM
Engine speed for setting ignition timing-California models	1150-1250 RPM

ITEM	TORQUE		NOTES
Air cleaner backplate screw	7-9 ft-lbs	9.5-12.2 Nm	LOCTITE THREADLOCKER 242 (blue), page 4-19
Air cleaner cover rear screw	6-8 ft-lbs	8.1-10.8 Nm	page 4-19
Air cleaner front support screw	3-5 ft-lbs	4.1-6.8 Nm	LOCTITE THREADLOCKER 242 (blue), page 4-19
Canister clamp screws	6-8 ft-lbs	8.1-10.8 Nm	page 4-25
Cylinder head breather bolts	10-15 ft-lbs	13.6-20.3 Nm	HYLOMAR, page 4-19
Fuel cap flange screws	22-25 in-lbs	2.5-2.8 Nm	special pattern to tighten, page 4-21
Fuel supply valve screws	34-37 in-lbs	3.8-4.2 Nm	page 4-22
Fuel tank screw	9-11 ft-lbs	12.2-14.9 Nm	page 4-21
Intake manifold screws	6-10 ft-lbs	8.1-13.6 Nm	page 4-17
Snorkel tube screw	6-8 ft-lbs	8.1-10.8 Nm	LOCTITE THREADLOCKER 242 (blue), page 4-19
Tie bar bolts	30-33 ft-lbs	40.7-44.7 Nm	page 4-17
Torx ignition bracket screw	25-30 ft-lbs	33.9-40.7 Nm	page 4-17

CARBURETOR

GENERAL

See Figure 4-1. Buell motorcycles use a constant-velocity, gravity-fed carburetor. This carburetor features a float-operated inlet valve, a variable venturi, a throttle stop screw (for idle speed adjustment) and a fuel enrichment system (for starting).

Idle and transfer ports provide a balanced fuel mixture during the transition period from stop to mid-range. A vacuum piston controls venturi opening.

The carburetor is specifically designed to control exhaust emissions. All jets are fixed. The idle mixture has been pre-set at the factory. The idle mixture screw is recessed in the carburetor casting. The opening is sealed with a plug because it is intended that the idle mixture be non-adjustable.

NOTE

Adjusting mixture setting by procedures other than specified in this section may be in violation of Federal or State regulations.

This system partially compensates for changes in the mixture that are normally caused by changes in altitude. Because atmospheric pressures drop as altitude increases, the pressure difference in the upper and lower chambers is reduced; this results in less fuel being delivered to the engine, thereby maintaining the correct air/fuel ratio for better engine performance and reduced exhaust emissions.

The carburetor has a drain for emptying the float chamber during seasonal or extended periods of storage.

The carburetor is equipped with an accelerator pump. The accelerator pump system uses sudden throttle openings (rapid accelerations) to quickly inject raw fuel into the carburetor venturi; this provides extra fuel for smooth acceleration.

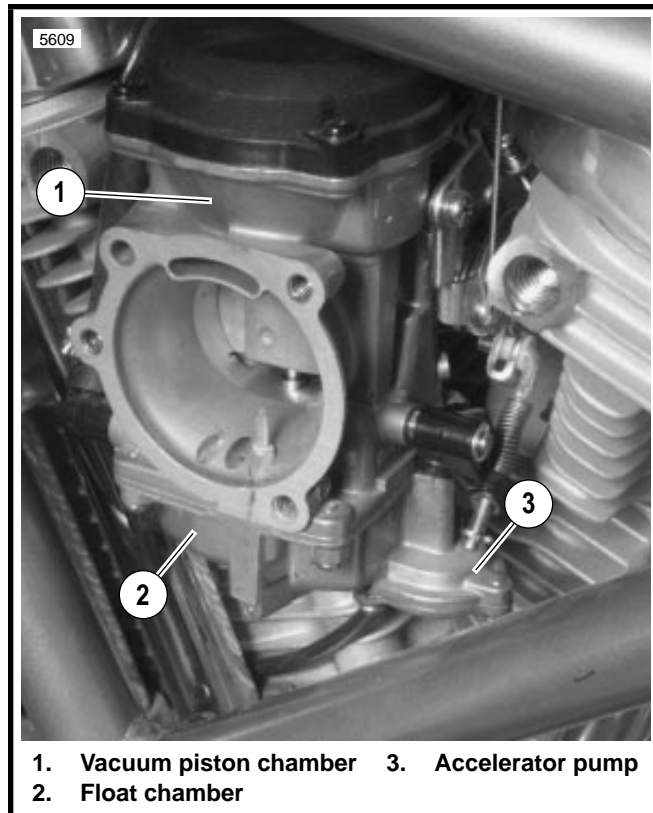

Figure 4-1. Carburetor

Table 4-1. Fuel System Troubleshooting

OVERFLOW	
<p>Check for:</p> <ol style="list-style-type: none"> 1. Restricted fuel tank vent system. 2. Loose float bowl screws. 3. Damaged float bowl O-ring. 4. Damaged or leaking float assembly. 5. Particle contamination in fuel inlet fitting cavity. 6. Worn or dirty inlet valve or seat. 7. Improper fuel level in float bowl. 	<p>Remedy:</p> <ol style="list-style-type: none"> 1. Correct restricted hose. Replace vapor vent valve. 2. Tighten screws. 3. Replace O-ring. 4. Replace float assembly. 5. Clean and clear cavity and fuel supply tract. 6. Clean or replace valve and clean seat. 7. Adjust float tab for correct fuel level.
POOR IDLING	
<p>Check for:</p> <ol style="list-style-type: none"> 1. Idle speed improperly adjusted. 2. Inlet system air leak (faster idling). 3. Loose low speed jet. 4. Contaminated or plugged low speed system. 5. Enrichener valve not seated or leaking. 6. Leaking accelerator pump. 	<p>Remedy:</p> <ol style="list-style-type: none"> 1. Adjust operating idle speed. 2. Correct as required. 3. Tighten jet. 4. Clean, clear and correct as required. 5. Adjust, clean or replace. 6. Repair.
POOR FUEL ECONOMY	
<p>Check for:</p> <ol style="list-style-type: none"> 1. Excessive use of enrichener system. 2. Enrichener valve not seated or leaking. 3. Dirty air cleaner filter element. 4. Restricted fuel tank vent system. 5. High speed riding style. 6. Idle speed improperly adjusted. 7. Loose jets. 8. Fuel level too high. 9. Plugged or restricted bowl vent. 10. Worn or damaged needle or needle jet. 11. Vacuum piston assembly malfunction. 12. Plugged air jets or passages. 13. Excessive accelerator pump output. 	<p>Remedy:</p> <ol style="list-style-type: none"> 1. Limit system use. 2. Adjust, clean or replace. 3. Clean or replace as required. 4. Correct restricted hose. Replace vapor vent valve. 5. Modify riding habits. 6. Adjust operating idle speed. 7. Tighten jets. 8. Adjust float tab for correct fuel level. 9. Clean and clear passages. 10. Replace needle or needle jet. 11. See Vacuum Piston Troubleshooting on page 4-4. 12. Clean, clear and correct as required. 13. Check and clean accelerator pump bypass orifice.
POOR ACCELERATION	
<p>Check for:</p> <ol style="list-style-type: none"> 1. Throttle cables misaligned. 2. Inlet system air leak. 3. Restricted fuel tank vent system. 4. Restricted fuel supply passages. 5. Plugged bowl vent or overflow. 6. Enrichener valve not seated or leaking. 7. Worn or damaged needle or needle jet. 8. Vacuum piston malfunction. 9. Plugged jets or passages. 10. Fuel level too low. 11. Accelerator pump leaking or no output. 	<p>Remedy:</p> <ol style="list-style-type: none"> 1. Adjust throttle cables. 2. Correct as required. 3. Correct restricted hose. Replace vapor vent valve. 4. Correct and clear restriction. 5. Clean and clear passages. 6. Adjust, clean or replace. 7. Replace assembly. 8. See Vacuum Piston Troubleshooting on page 4-4. 9. Clean and clear as required. 10. Adjust float tab for correct fuel level. 11. Repair as necessary.
HARD STARTING	
<p>Check for:</p> <ol style="list-style-type: none"> 1. Enrichener system plugged, not properly functioning or improperly operated. 2. Inlet system air leak. 3. Restricted fuel supply. 4. Fuel overflow. 5. Plugged slow jet or passages. 	<p>Remedy:</p> <ol style="list-style-type: none"> 1. Clean, adjust or replace; or read Owner's Manual. 2. Correct as required. 3. Correct fuel supply or passages. 4. See Overflow Troubleshooting on page 4-3. 5. Clean, clear and correct as required.

Table 4-1. Fuel System Troubleshooting (cont.)

POOR PERFORMANCE ON ROAD	
<p>Check for:</p> <ol style="list-style-type: none"> 1. Idle speed improperly adjusted. 2. Inlet system air leak. 3. Restricted fuel tank vent system. 4. Dirty or damaged air cleaner element. 5. Enrichener valve not seated or leaking. 6. Restricted fuel supply tract. 7. Plugged bowl vent or overflow. 8. Loose or plugged fuel and air jets or passages. 9. Worn or damaged needle or needle jet. 10. Vacuum piston assembly malfunction. 11. Accelerator pump inoperative. 	<p>Remedy:</p> <ol style="list-style-type: none"> 1. Adjust operating idle speed. 2. Correct as required. 3. Correct restricted hose. Replace vapor vent valve. 4. Clean or replace. 5. Adjust, clean or replace. 6. Correct and clear restriction. 7. Clean and clear passages. 8. Clean, clear and correct as required. 9. Replace assembly. 10. See Vacuum Piston Troubleshooting below. 11. Repair as required.
POOR HIGH-SPEED PERFORMANCE	
<p>Check for:</p> <ol style="list-style-type: none"> 1. Inlet system air leak. 2. Enrichener valve not seated or leaking. 3. Restricted fuel tank vent system. 4. Restricted fuel supply tract. 5. Dirty or damaged air cleaner element. 6. Plugged bowl, vent or overflow. 7. Worn or damaged needle or needle jet. 8. Vacuum piston assembly malfunction. 9. Loose or plugged main jets or passages. 10. Improper fuel level. 11. Accelerator pump inoperative. 	<p>Remedy:</p> <ol style="list-style-type: none"> 1. Clean or replace. 2. Adjust, clean or replace. 3. Correct restricted hose. Replace vapor vent valve. 4. Correct and clean restriction. 5. Clean or replace. 6. Clean and clear passages. 7. Replace assembly. 8. See Vacuum Piston Troubleshooting below. 9. Clean, clear and correct as required. 10. Adjust float level. 11. Repair as required.

Table 4-2. Vacuum Piston Assembly Troubleshooting

PISTON DOES NOT RISE PROPERLY	
<p>Check for:</p> <ol style="list-style-type: none"> 1. Piston atmosphere vent blocked. 2. Diaphragm cap loose, damaged or leaking. 3. Spring binding. 4. Diaphragm pinched at lip groove. 5. Torn diaphragm. 6. Piston binding. 7. Piston vacuum passage plugged. 	<p>Remedy:</p> <ol style="list-style-type: none"> 1. Clear vent. 2. Tighten or replace cap. 3. Correct or replace spring. 4. Reposition diaphragm lip. 5. Replace piston diaphragm assembly. 6. Clean piston slides and body or replace piston. 7. Clean and clear passage.
PISTON DOES NOT CLOSE PROPERLY	
<p>Check for:</p> <ol style="list-style-type: none"> 1. Spring damaged. 2. Piston binding. 3. Piston diaphragm ring dirty or damaged. 	<p>Remedy:</p> <ol style="list-style-type: none"> 1. Replace spring. 2. Clean piston slides and body or replace piston. 3. Clean or replace piston.

OPERATION

Enrichener

The enrichener knob, next to the ignition switch, controls the opening and closing of the enrichener valve at the carburetor.

⚠ CAUTION

Avoid idling with the enrichener knob in the full out position for periods longer than 30 seconds. Such operation may cause poor performance, erratic idle, poor fuel economy and spark plug fouling.

NOTE

The 1996 C.V. carburetor has an enrichener circuit that will cause the engine to idle at approximately 2000 RPM with the engine at normal operating temperature and the enrichener knob pulled fully out.

The increase in idle speed is intended to alert the rider that the engine is warmed up to normal operating temperature and the enrichener knob should be pushed all the way in.

Continuing to use the enrichener when the engine is at full operating temperature WILL CAUSE FOULED PLUGS.

IMPORTANT NOTE

This motorcycle features a starter interlock. All the following conditions must be met to operate the engine starter.

- **Engine stop switch on right handlebar control group must be in the RUN (ignition ON) position.**
- **Clutch must be disengaged before starting motorcycle in gear. Note that it is not necessary to disengage clutch before starting the vehicle in neutral.**
- **Side stand must be retracted before the clutch is engaged if the motorcycle is in gear.**

See **STARTER INTERLOCK** in Section 7 for troubleshooting information.

COOL ENGINE

OUTSIDE TEMPERATURE COOLER THAN 50° F

1. Set engine stop switch to RUN.
2. Raise side stand.
3. Turn fuel supply valve ON.
4. Turn ignition key switch to IGN.
5. **BE SURE THROTTLE IS CLOSED.** Pull enrichener knob to full out position.
6. Press electric starter switch to operate starter.

After starting the motorcycle, proceed as follows:

1. After initial 15-30 second warm-up, ride for 5 minutes or 3 miles with enrichener knob in full out position.
2. After 5 minutes or 3 miles, push enrichener knob in to the 1/2 way position. Ride 2 minutes or 2 miles.
3. After 2 minutes or 2 miles, push enrichener knob fully in.

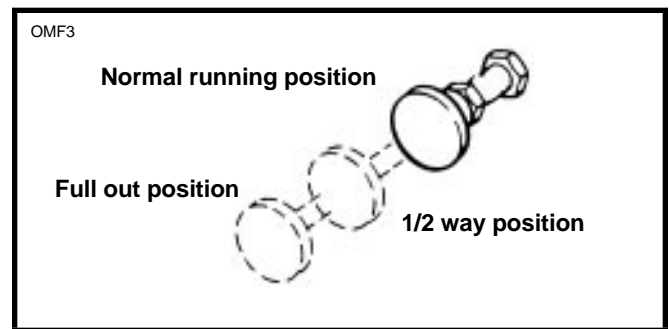

Figure 4-2. Enrichener Knob Positions

COOL ENGINE

OUTSIDE TEMPERATURE WARMER THAN 50° F

1. Set engine stop switch to RUN.
2. Raise side stand.
3. Turn fuel supply valve ON.
4. Turn ignition key switch to IGN.
5. **BE SURE THROTTLE IS CLOSED.** Pull enrichener knob to full out position.
6. Press electric starter switch to operate starter.

After starting the motorcycle, proceed as follows:

1. After initial 15-30 second warm-up, ride for 3 minutes or 2 miles with enrichener knob in full out position.
2. After 3 minutes or 2 miles, push enrichener knob in to the 1/2 way position. Ride 2 minutes or 2 miles.
3. After 2 minutes or 2 miles, push enrichener knob fully in.

WARM OR HOT ENGINE

1. Set engine stop switch to RUN.
2. Raise side stand.
3. Turn fuel supply valve ON.
4. Turn ignition key switch to IGN.
5. **DO NOT USE ENRICHENER.** Open throttle 1/8-1/4.
6. Press electric starter switch to operate starter.

NOTE

If the engine does not start after a few turns or if one cylinder fires weakly but engine does not start, it is usually because of an over-rich (flooded) condition. This is especially true of a hot engine. If the engine is flooded, push the enrichener knob fully in, turn ignition key switch to IGN and operate starter with throttle wide open. Do not "pump" the throttle while starting.

Fuel Supply System

See Figure 4-3. Fuel from the fuel tank passes through the carburetor inlet valve into the carburetor float chamber. The rising fuel level in the float chamber lifts the float, which in turn lifts the attached inlet valve closer to the valve seat. When the fuel reaches the level predetermined by the float level setting, the float will lift the inlet valve into its seated position, thereby closing the valve and stopping fuel flow to the float chamber.

When fuel is used by the running engine, the fuel level in the float chamber drops; this lowers the float and inlet valve, thereby causing the valve to open and the fuel flow to resume.

The float chamber is vented to atmosphere through an air passage in the carburetor body. The opening for the float chamber vent passage is next to the carburetor main venturi inlet, on the carburetor body surface to which the air cleaner backplate is mounted.

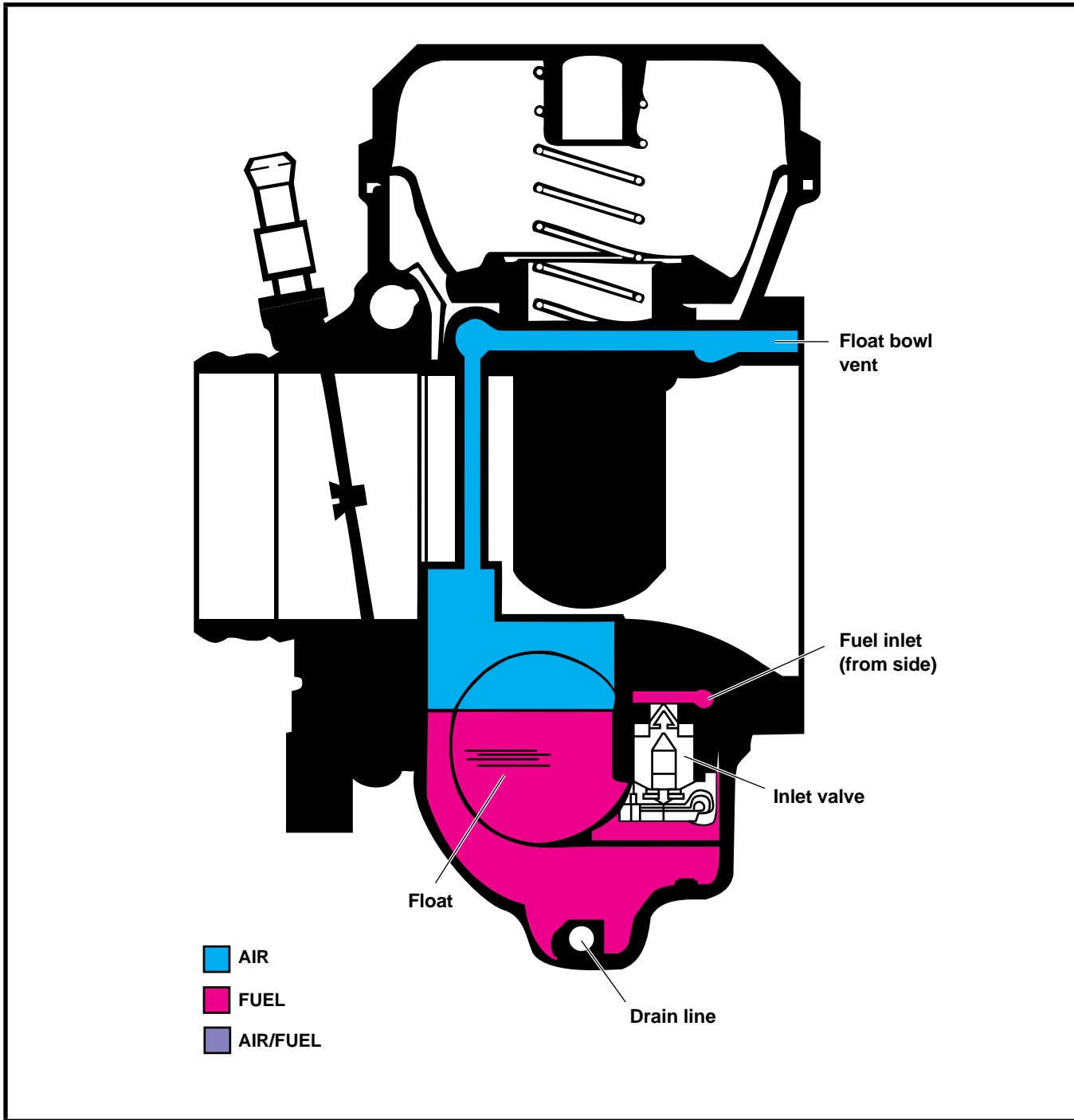

Figure 4-3. Fuel Supply System

Starting Circuit

See Figure 4-4. The starting circuit consists of a cable-actuated enricher valve and converging fuel and air passages in the carburetor body.

The enricher air/fuel passage opens to the carburetor venturi, where low pressure exists when the engine is running. Fuel in the carburetor float bowl and air in the enricher air inlet are vented to atmosphere and are at atmospheric pressure (greater pressure than in the carburetor venturi).

When the enricher knob is pulled outward, the enricher valve opens the air/fuel passage to the low pressure carburetor venturi. Fuel in the float bowl, at atmospheric pressure, flows upward through a metering enricher jet and then through a passage to the lower pressure enricher valve chamber. Air in the enricher air inlet, at atmospheric pressure, also flows into the lower pressure enricher valve chamber and mixes with the incoming fuel. The resulting air/fuel mixture flows through the air/fuel passage into the carburetor venturi, effectively increasing the amount of fuel delivered to the combustion chambers.

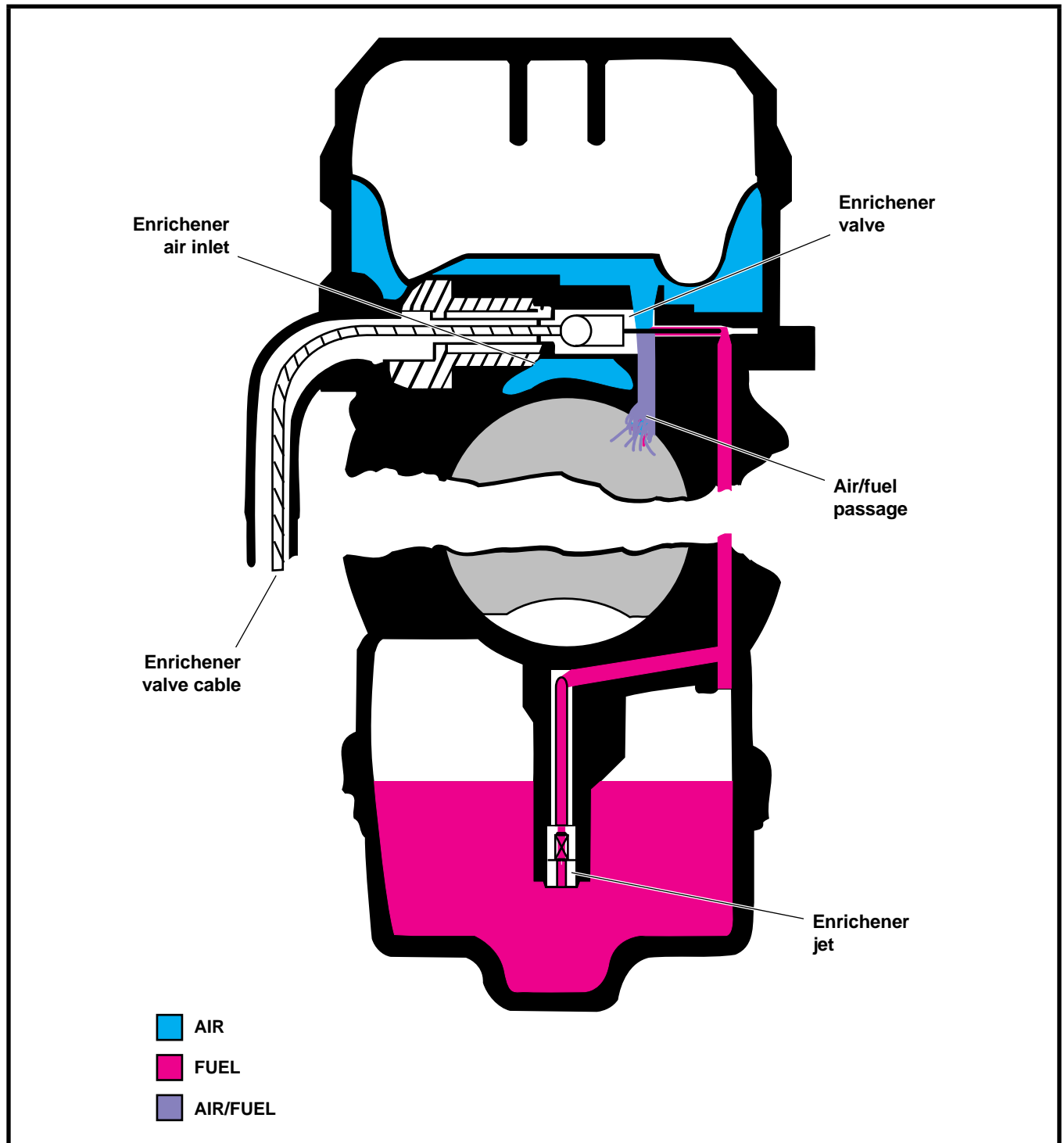

Figure 4-4. Starting Circuit

Idle- and Low-Speed Circuit

See Figure 4-5. At idle (with the throttle plate closed and the main air stream obstructed), engine idle speed is maintained by fuel metered through the slow jet. Air from the slow air jet mixes with the fuel and is delivered to the idle port at the low pressure side of the throttle plate.

At low-speed (with the throttle plate slightly open), the transfer ports are exposed to the low pressure side of the throttle plate, and additional fuel is directed to the barrel of the carburetor.

During the transition period from idle speed to mid-range, the idle and transfer ports also supply some fuel to the carburetor barrel; this allows for a smoother transition.

The venturi opening is reduced by the low position of the vacuum piston. This enables initial air stream velocities to be higher than normally attainable with fixed-venturi carburetors. The higher air stream velocities provide improved atomization of fuel necessary for good acceleration and driveability.

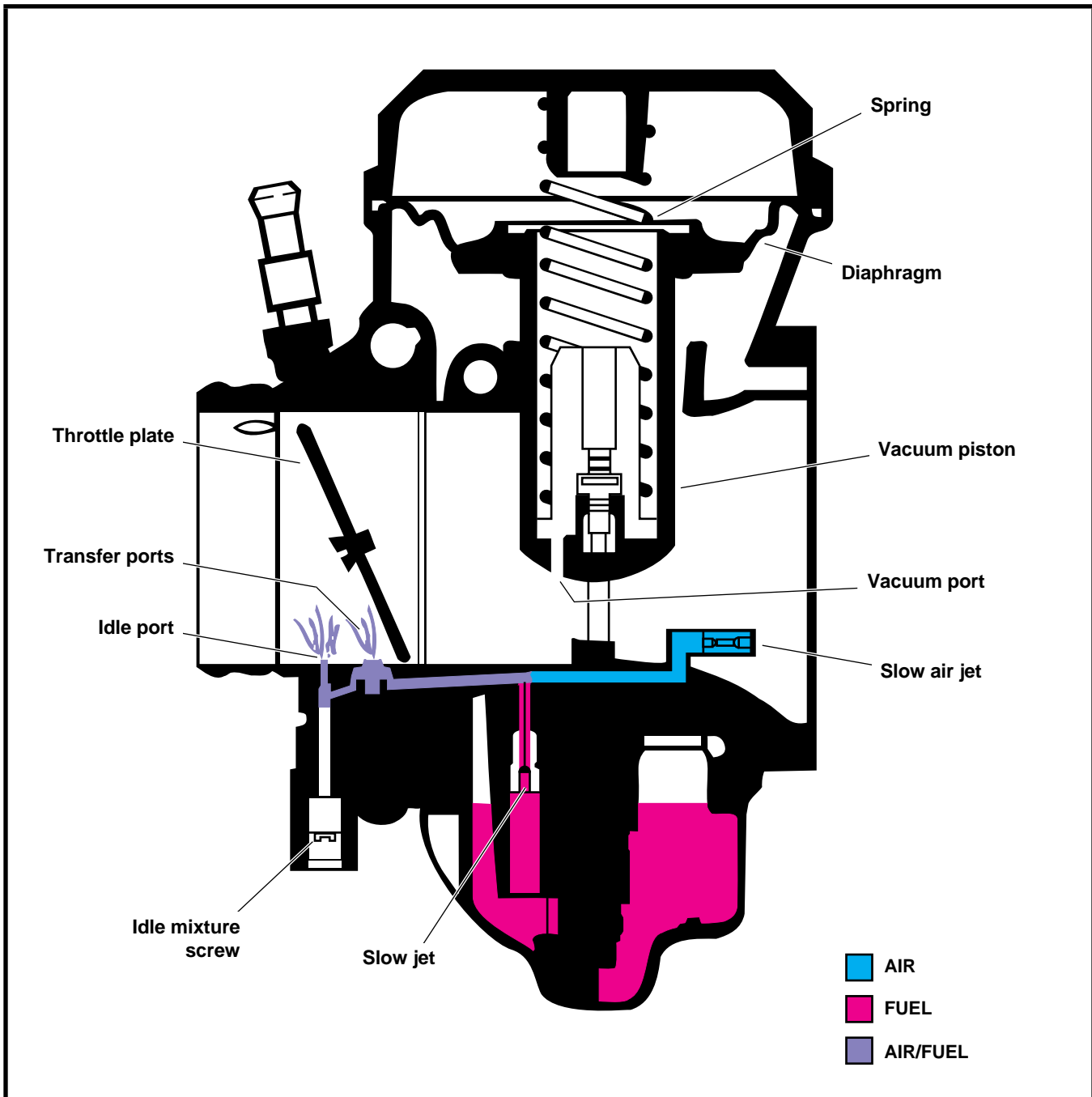

Figure 4-5. Idle- and Low-Speed Circuit

Mid-Range Slide Position

See Figure 4-6. As the throttle plate is opened, air flow increases through the carburetor; this causes air pressure to decrease in the carburetor venturi (near the needle jet) and in the chamber above the diaphragm (which is vented to the venturi through a vacuum port and passage in the vacuum piston).

The chamber beneath the diaphragm is vented to higher atmospheric pressure by a passage to the carburetor inlet. The higher air pressure at the underside of the diaphragm overcomes spring pressure and moves the vacuum piston upward in proportion to the pressure difference between the chambers.

The tapered needle moves upward with the vacuum piston, thereby opening the needle jet. With the needle jet open, the main bleed tube is exposed to the lower pressure of the carburetor venturi. This causes fuel in the float bowl (at atmospheric pressure) to flow through the main jet and into the main bleed tube. Air from the main air jet (at atmospheric pressure) flows through the main bleed tube openings and mixes with the incoming fuel. The air/fuel mixture is then delivered through the needle jet into the main air stream of the venturi.

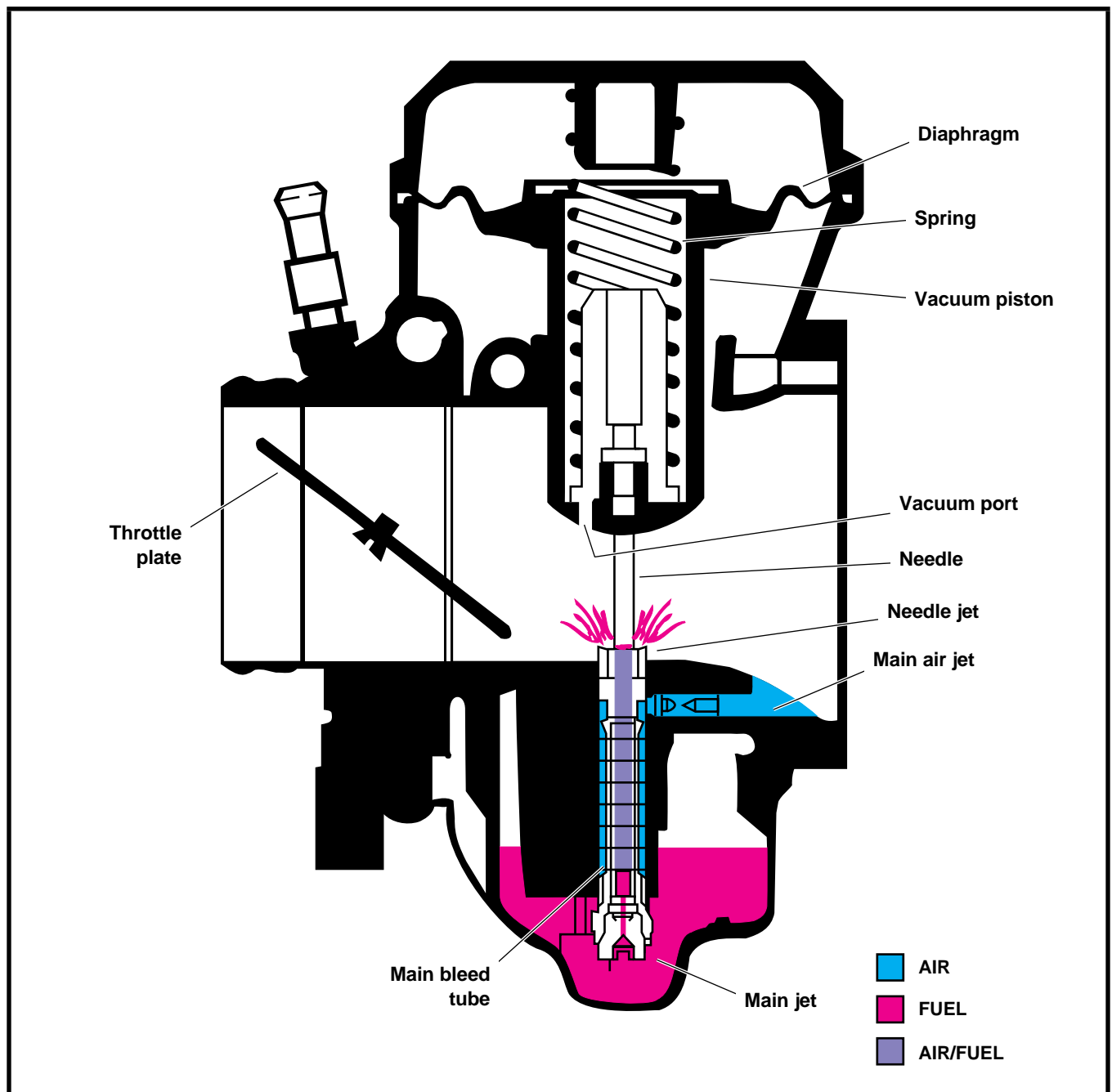

Figure 4-6. Mid-Range Slide Position

High-Speed Circuit Slide Position

See Figure 4-7. As the throttle plate is opened, the pressure difference between the chambers above and below the diaphragm increases and the vacuum piston moves further upward.

The venturi opening increases and the needle is lifted further out of the needle jet. The quantity of fuel and the volume of air are simultaneously increased and metered to the proportions of engine demand by the variable venturi and needle lift. With the vacuum piston fully upward, the venturi opening is fully enlarged and the needle jet opening exposure to the air stream is at its maximum. Air and fuel supplies are now available in quantities sufficient to meet maximum engine demand.

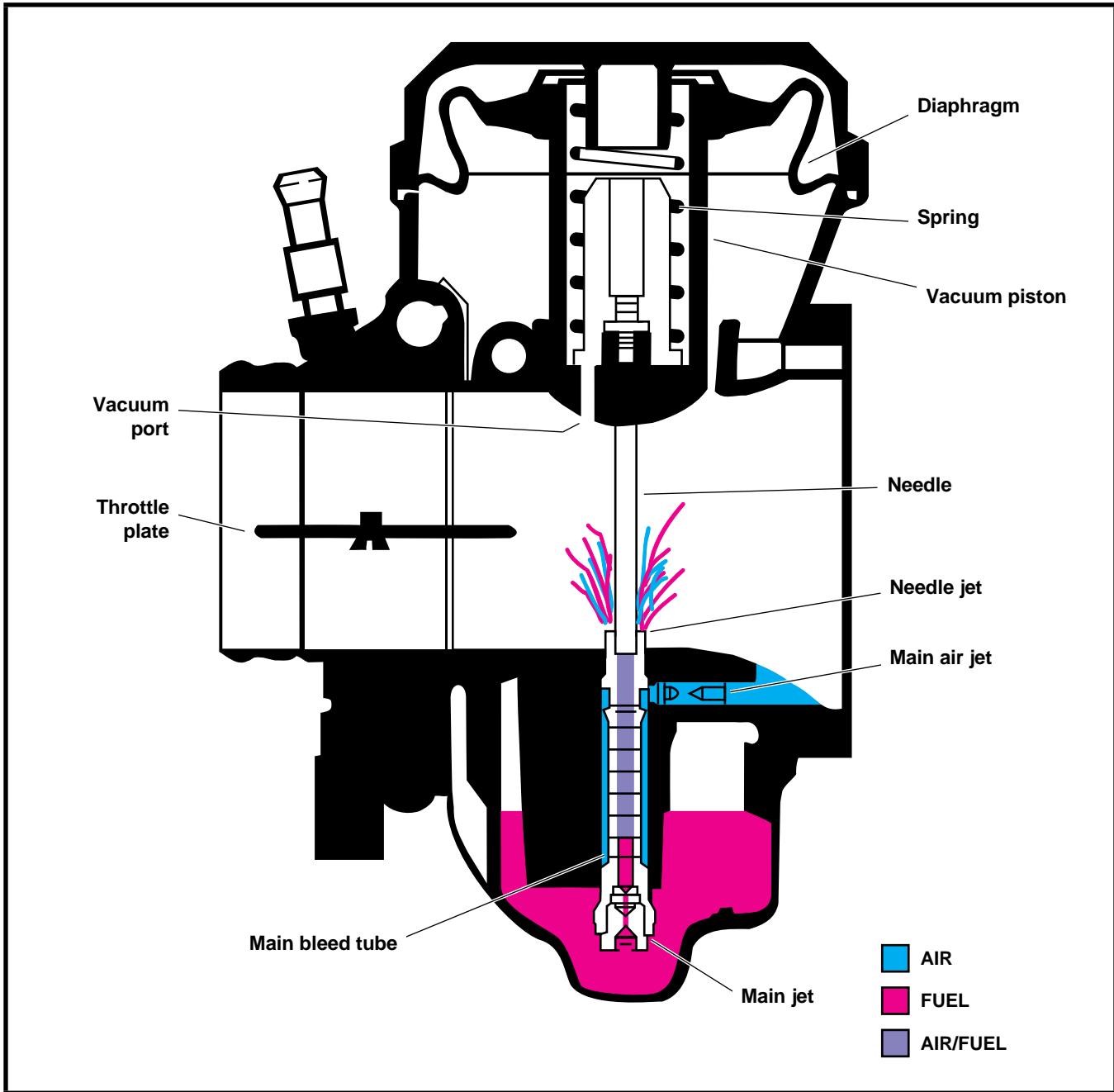

Figure 4-7. High-Speed Circuit

Accelerator Pump System

See [Figure 4-8](#). The accelerator pump system uses sudden throttle openings (rapid acceleration) to quickly inject fuel into the carburetor venturi; the extra fuel provides for smooth acceleration. This fuel also assists engine operation during cold engine warm-up when the enrichener is turned off prematurely.

Rapid throttle action, during the first third of throttle travel, causes the accelerator pump rod to depress the accelerator

pump diaphragm. This forces fuel in the pump to flow through a fuel passage (which has a "one-way" check valve), through the pump nozzle, and then into the venturi. When the throttle closes, the pump rod lifts up and away from the pump diaphragm; a spring below the diaphragm pushes the diaphragm upward, thereby causing the lower pump cavity to refill with fuel from the float bowl. The check valve prevents backflow of fuel from the pump nozzle/fuel passage during this refilling phase.

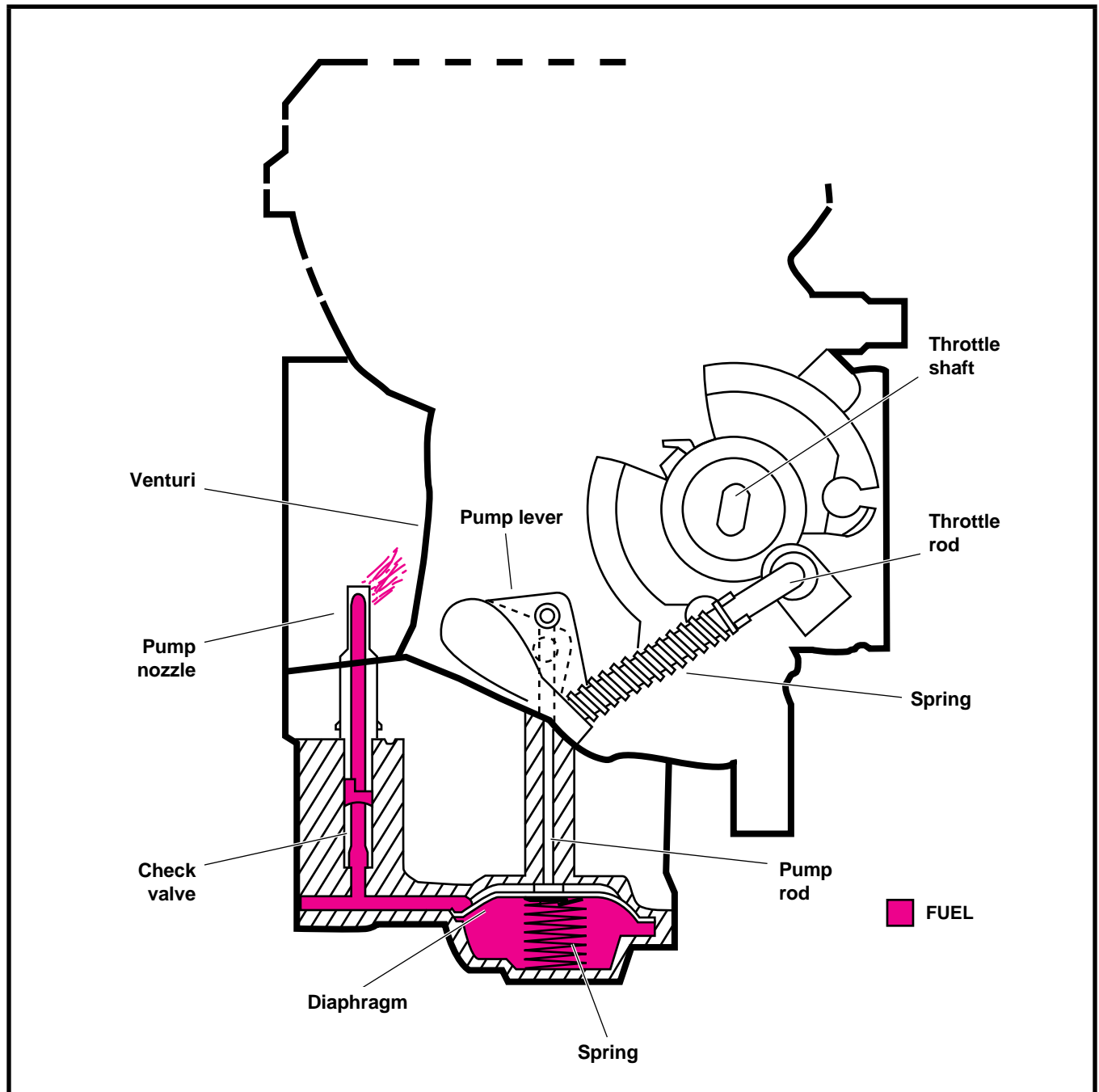

Figure 4-8. Accelerator Pump System

ADJUSTMENT

Idle

See [IGNITION TIMING](#) in Section 1.

Enrichener Control

See [Figure 4-9](#). Check enrichener operation. Enrichener knob (1) should open (and remain open) and close without binding. Plastic nut (2), next to the enrichener knob, controls the sliding resistance of the enrichener control cable within the cable conduit. If adjustment is needed, perform the following:

1. Loosen hex nut (5) at backside of mounting bracket.
2. Move cable assembly free of slot in mounting bracket.
3. Hold cable assembly at flats (4) with a wrench. Adjust resistance until knob slides outward and remains fully open without assistance. Knob must also slide inward unaided.
 - a. Turn plastic nut (2) by hand counterclockwise (reducing sliding resistance).
 - b. Turn plastic nut clockwise (increasing sliding resistance).
4. Position cable assembly into slot in mounting bracket. Tighten hex nut at backside of bracket.

NOTE

Do not lubricate the cable or inside of conduit. The cable must have friction to work properly.

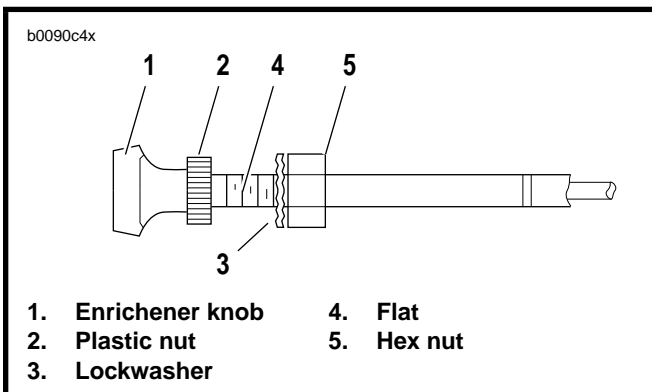

Figure 4-9. Fuel Enrichener Control

Float Level

1. Remove carburetor and place on a flat, clean surface on engine manifold side. This is the "base." Tilt carburetor counterclockwise 15° to 20° from base until float comes to rest. See [Figure 4-11](#).

NOTE

If carburetor is tilted less than 15° or more than 20°, your measurements will be inaccurate.

2. Use a vernier or dial caliper depth gauge to measure from the carburetor flange face to the perimeter of the float. Be careful not to push on float while measuring. The measurement must be 0.413-0.453 in. (10.49-11.51 mm). If measurement is not within given dimension, remove float and carefully bend tab in order to reposition float at proper level.

3. Install float and recheck setting.
4. Install float bowl. Install carburetor as described in [CARBURETOR, INSTALLATION](#) on page 4-17.

OPERATION CHECK – VACUUM PISTON

Opening Malfunction

⚠WARNING

While observing piston slide movement, be sure to maintain a safe distance from the carburetor and to wear suitable eye protection. An unexpected engine backfire could cause personal injury.

1. See [Figure 4-10](#). Test vacuum piston as follows.
 - a. Remove air cleaner cover and snorkel.
 - b. Start engine running.
 - c. Twist throttle control partially open and closed several times.Observe whether or not vacuum piston has upward movement. If piston does not rise, see [VACUUM PISTON ASSEMBLY TROUBLESHOOTING](#) on page 4-4.
2. With engine not running, lift vacuum piston with finger. Feel whether piston lifts fully and smoothly or whether there is a binding condition.

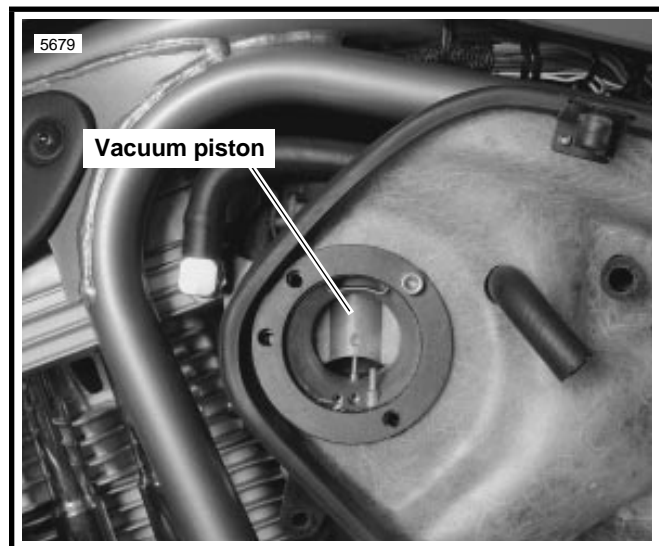
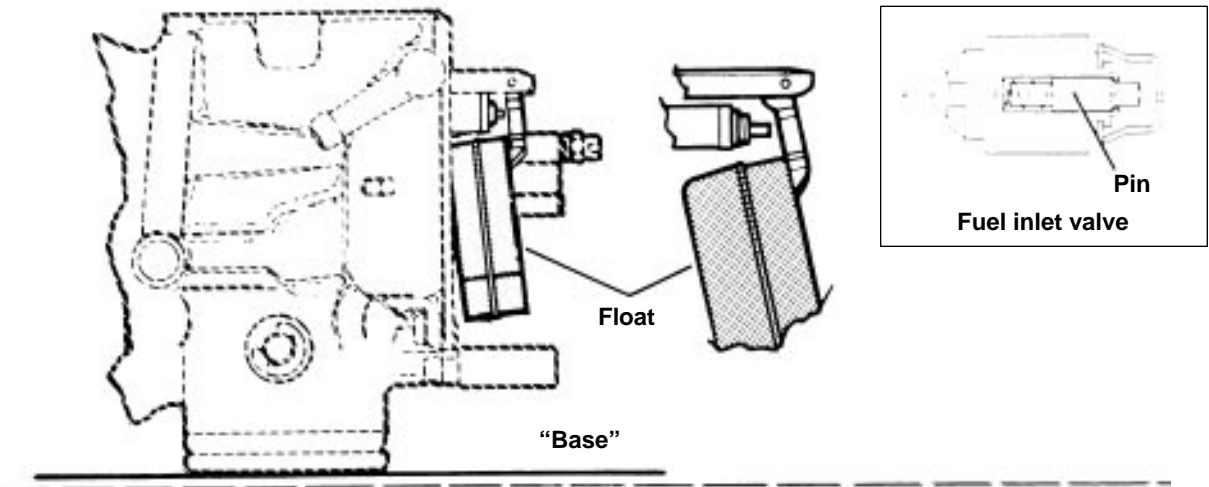

Figure 4-10. Vacuum Piston

Closing Malfunction

1. See [Figure 4-10](#). With engine not running, lift vacuum piston to full open position, then release. Observe whether piston slides downward smoothly and fully to stop.
2. Observe position of piston slide at its lowest downward point. Lower edge of slide should rest at horizontal groove at lower end of slide track. See [VACUUM PISTON ASSEMBLY TROUBLESHOOTING](#) on page 4-4 if problems are noted.

Start float position



Correct float position

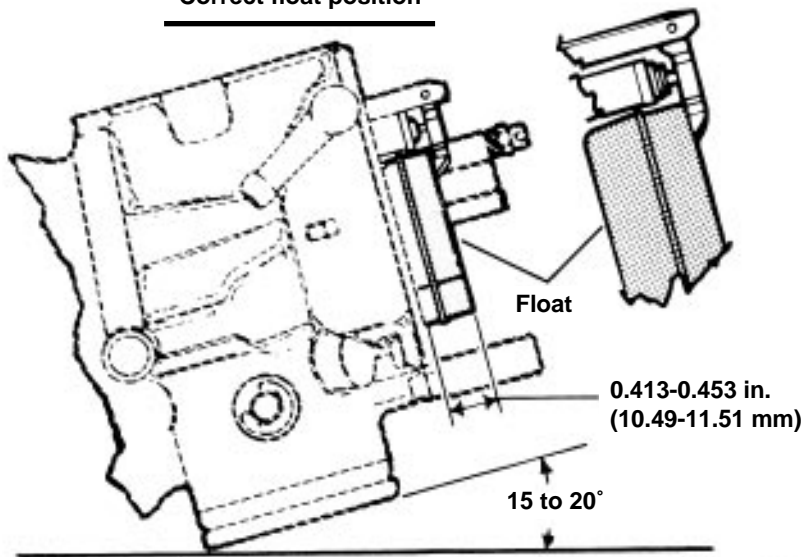

Incorrect float position

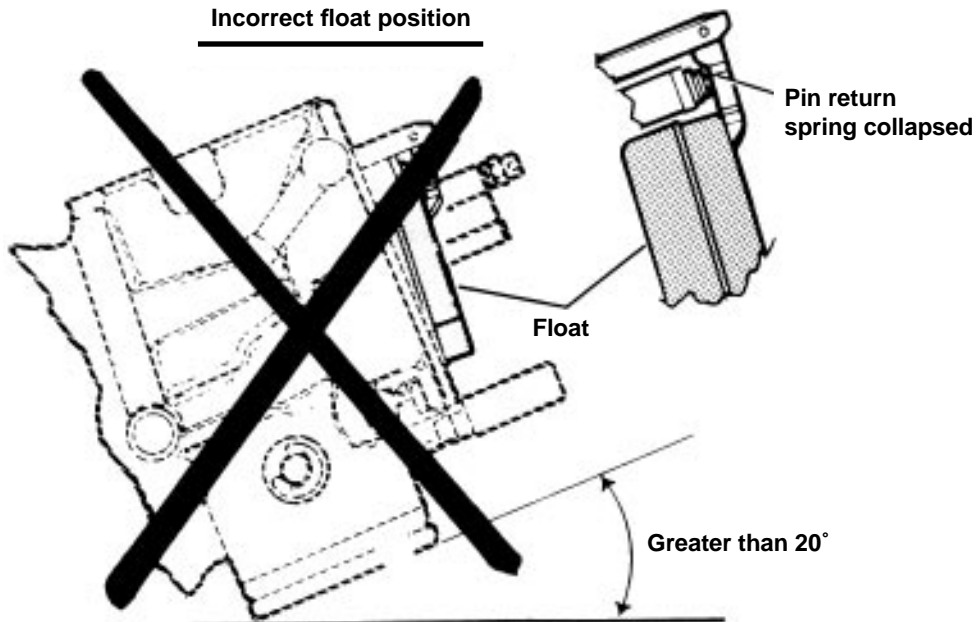

Figure 4-11. Carburetor Float Adjustment

REMOVAL

Carburetor

⚠ WARNING

Gasoline can be extremely flammable and highly explosive. Do not smoke or allow open flame or sparks when refueling or servicing the fuel system. Inadequate safety precautions may result in personal injury.

1. Turn fuel supply valve OFF.
2. Remove air cleaner cover and backplate. See [AIR CLEANER, REMOVAL](#) on [page 4-18](#).
3. Loosen rear breather bolt. Remove front breather bolt and washer. Remove air cleaner support ring.

⚠ WARNING

A small amount of gasoline may drain from the fuel hose when disconnected from the carburetor. Thoroughly wipe up any spilt fuel immediately and dispose of rags in a suitable manner. Gasoline can be extremely flammable and highly explosive. Inadequate safety precautions may result in personal injury.

4. See [Figure 4-12](#). Disconnect fuel hose from carburetor. Discard fuel hose clamp.
5. Detach enricher cable from bracket near ignition key switch.
6. Disconnect vacuum hose from carburetor V.O.E.S. fitting.
7. Add freeplay to throttle cable adjusters (metric). Remove throttle cables at carburetor.
8. Pull carburetor free of intake manifold.
9. Disconnect fuel drain hose from drain fitting. On California models, disconnect canister vent hose.

Carburetor Manifold

1. Remove carburetor as described above.
2. Remove fuel tank. See [FUEL TANK, REMOVAL](#) on [page 4-20](#).
3. Remove ignition key switch bracket.
 - a. Remove bolt and locknut to detach top tie bar from ignition key switch bracket.
 - b. Cut cable strap holding ignition wires to main wiring harness.
 - c. Remove two TORX screws and washers from cylinder heads.
 - d. Place bracket to the side.
4. See [Figure 4-13](#). Loosen two intake manifold screws (4) on primary side of engine. Do not remove.
5. Remove two manifold mounting screws (4) on gearcase side of engine.
6. Remove intake manifold (5) and seal ring (6). Slide both mounting flanges (1, 2) over primary side screws (4). Remove intake manifold seals (3).

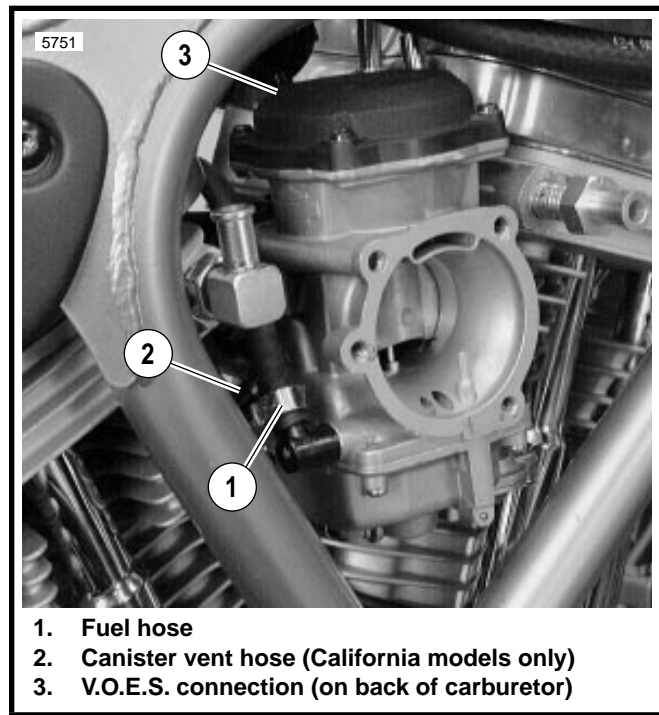

Figure 4-12. Carburetor Hoses

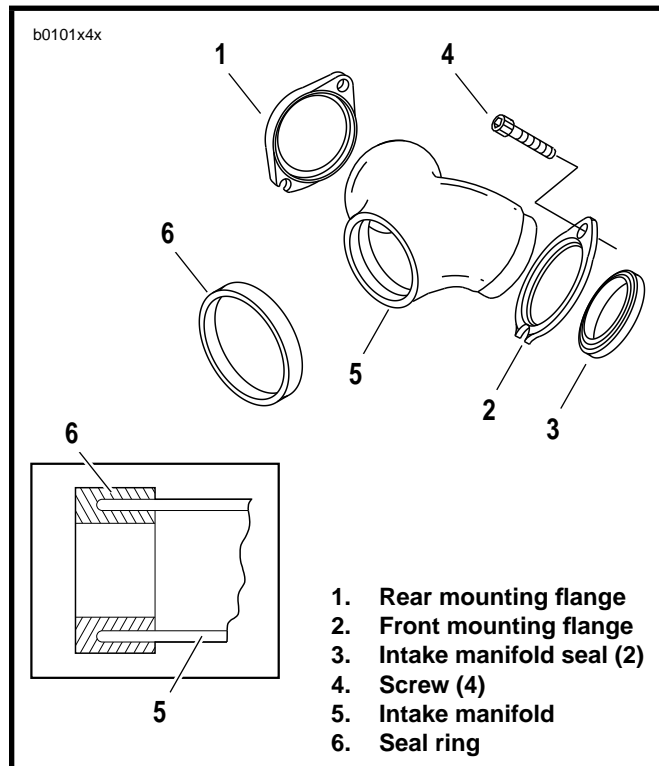

Figure 4-13. Intake Manifold

DISASSEMBLY

Vacuum Piston Chamber

1. See [Figure 4-14](#). Remove screws (26, 25) and throttle cable bracket (24).
2. Remove three shouldered screws (2). Remove top cover (1) and spring (3).
3. Lift out vacuum piston (4) with jet needle (6) and spring seat (5). Remove loose parts from vacuum piston.

Carburetor Body

1. See [Figure 4-14](#). Remove four screws and lockwashers (18). Remove float bowl assembly (38).
2. Remove pin (14), float (16) and fuel inlet valve (13).
3. Back out main jet (11) and needle jet holder (10). Needle jet (9) is free to be removed from bottom end of passage.
4. Insert thin-bladed screwdriver into slow jet passage to remove slow jet (12).

Accelerator Pump

1. Remove three screws (49), lockwashers (48), accelerator pump housing (42), spring (43) and diaphragm (44). Remove O-ring (45) from housing.

CLEANING, INSPECTION AND REPAIR

Vacuum Piston Components

1. See [Figure 4-14](#). Hold vacuum piston up to strong light. Examine diaphragm at top of vacuum piston (4) for evidence of pinching, holes or tears. Replace if damaged.
2. Examine vacuum passage through bottom of piston (4). Clean passage if restricted.
3. Examine spring (3) for stretching, crimping, distortion or damage. Replace if necessary.
4. Examine slide on sides of piston (4) to be sure surface is smooth and clean. Clean or buff out any rough surfaces.
5. Examine jet needle (6) for evidence of bending or damage. Needle should be straight; surface of taper should be smooth and even.
6. Check float bowl O-ring (53) for any distortion or damage. Replace if seating surfaces are damaged.
7. Examine fuel inlet valve (13) and inlet valve seat. Clean with carburetor cleaner. Replace if seating surfaces are damaged.
8. Clean slow jet (12) with carburetor cleaner. Check to be sure all orifices are open.
9. Check enrichener valve (22). Be sure needle guide is clean, straight and undamaged. Check composition seating surface for wear or damage. Replace if damaged.
10. Check enrichener valve chamber. Clean with carburetor cleaner. Check that all passages are open and free of obstruction.
11. Clean needle jet (9). Replace if damaged.

12. Clean all internal fuel/air passages and jets. Check that all passages and jets are open and free of obstruction.
13. Check needle jet holder (10). Clean bleed tube orifices. Replace holder if damaged.
14. Check float (16) for cracks or other leaks. Replace if damaged.
15. Clean main jet (11) with carburetor cleaner and inspect for damage. Replace if damaged.

Accelerator Pump

1. See [Figure 4-14](#). Inspect the accelerator pump diaphragm (44) for holes, cracks or deformation. Replace as necessary.
2. Replace the accelerator pump rod (51) if it is bent; replace the boot (50) if cracked.

ASSEMBLY

Vacuum Piston Chamber

1. See [Figure 4-14](#). Place jet needle (6) through center hole in vacuum piston (4). Place spring seat (5) over top of needle.
2. Insert vacuum piston (4) into carburetor body. The slides on the piston are off-center and the piston will fit into the slide track grooves one way only. If piston does not fit, rotate 180°.
3. Check to be sure diaphragm is seated evenly into groove at top of carburetor body. Place spring (3) over spring seat (5), and carefully lower top cover (1). Keep spring straight while lowering top cover.
4. After top cover (1) is seated, hold top cover while lifting vacuum piston (4) upward. Piston should raise to top smoothly. If piston movement is restricted, spring (3) is cocked; lift up top cover, then lower carefully, keeping spring coils straight.
5. Once top cover is installed correctly, install three shouldered screws (2). Place throttle cable bracket (24) in position with idle screw (27), resting on top of throttle cam stop. Install body screw and washer (26) first, then top screw (25) to prevent bending bracket or throttle cam.

Carburetor Body

CAUTION

Slow jets from fixed-venturi carburetors look the same as the slow jet of the C.V. carburetor. However, the air bleed hole sizes are different on fixed-venturi carburetors and they must not be installed on C.V. carburetors.

1. See [Figure 4-14](#). Thread slow jet (12) into slow jet passage with narrow-bladed screwdriver.
2. Turn carburetor upside down. Place needle jet (9) in main jet passage with needle passing through center hole. Be sure end of jet with larger opening and chamfered surface enters passage first.

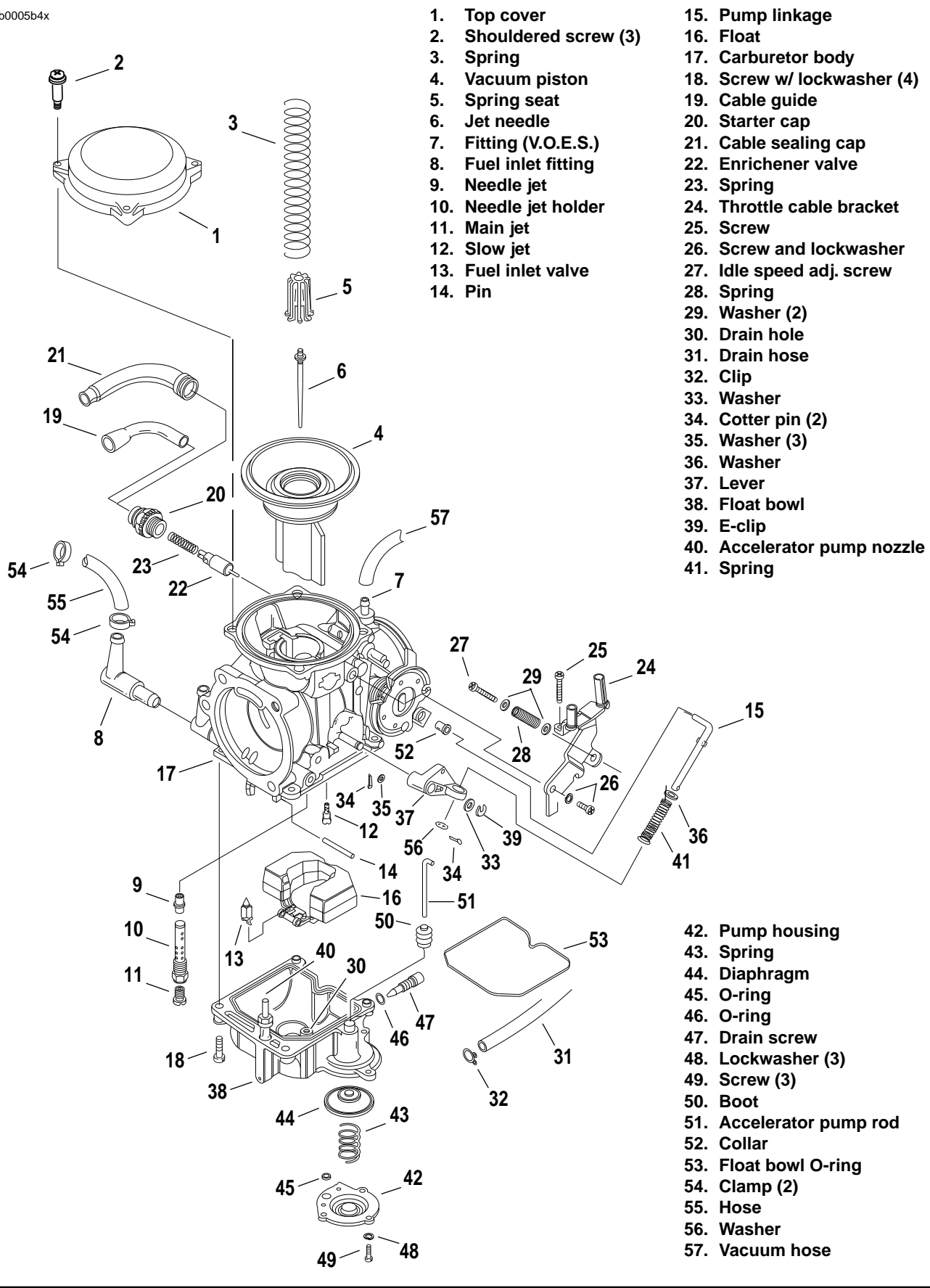

- 1. Top cover
- 2. Shouldered screw (3)
- 3. Spring
- 4. Vacuum piston
- 5. Spring seat
- 6. Jet needle
- 7. Fitting (V.O.E.S.)
- 8. Fuel inlet fitting
- 9. Needle jet
- 10. Needle jet holder
- 11. Main jet
- 12. Slow jet
- 13. Fuel inlet valve
- 14. Pin

- 15. Pump linkage
- 16. Float
- 17. Carburetor body
- 18. Screw w/ lockwasher (4)
- 19. Cable guide
- 20. Starter cap
- 21. Cable sealing cap
- 22. Enrichener valve
- 23. Spring
- 24. Throttle cable bracket
- 25. Screw
- 26. Screw and lockwasher
- 27. Idle speed adj. screw
- 28. Spring
- 29. Washer (2)
- 30. Drain hole
- 31. Drain hose
- 32. Clip
- 33. Washer
- 34. Cotter pin (2)
- 35. Washer (3)
- 36. Washer
- 37. Lever
- 38. Float bowl
- 39. E-clip
- 40. Accelerator pump nozzle
- 41. Spring

- 42. Pump housing
- 43. Spring
- 44. Diaphragm
- 45. O-ring
- 46. O-ring
- 47. Drain screw
- 48. Lockwasher (3)
- 49. Screw (3)
- 50. Boot
- 51. Accelerator pump rod
- 52. Collar
- 53. Float bowl O-ring
- 54. Clamp (2)
- 55. Hose
- 56. Washer
- 57. Vacuum hose

Figure 4-14. Constant-Velocity (C.V.) Carburetor

- 
3. Insert needle jet holder (10) into main jet passage with needle inserted into center of holder. Thread holder into passage and tighten. Thread and tighten main jet (11) in tapped hole in needle jet holder (10).
 4. Place float assembly (16) into position with fuel inlet valve (13) inserted into valve seat and with pivot arm aligned with holes in mounting posts (at bottom of carburetor body). Insert pin (14) through float pivot arm and float mounting posts.
 5. Check float level setting and adjust if necessary. See [FLOAT LEVEL](#) on [page 4-12](#).
 6. Place float bowl (38) over float and onto carburetor body flange. Bowl will only fit in one position. Install and tighten screws and lockwashers (18).

Accelerator Pump

Install diaphragm (44), spring (43), O-ring (45) and pump housing (42). Secure with screws (49) and lockwashers (48).

INSTALLATION

Carburetor Manifold

1. See [Figure 4-13](#). Place mounting flanges (1, rear and 2, front) on aluminum manifold (5).
2. Place intake manifold seals (3) on each spigot of manifold with chamfered edge against mounting flanges (1, 2).
3. Place channel of seal ring (6) over inlet end of manifold.
4. Position manifold against intake ports of cylinder head, with slotted and round holes in flanges (1, 2) aligned with holes in cylinder head. Manifold should slide over screws on primary side of engine. Insert two screws (4) through manifold flanges on gearcase side and loosely thread into tapped holes in cylinder head. Tighten intake manifold screws (4) to 6-10 ft-lbs (8.1-13.6 Nm).
5. Install ignition key switch bracket.
 - a. Fasten bracket to cylinder heads with two TORX screws and washers. Tighten to 25-30 ft-lbs (33.9-40.7 Nm).
 - b. Attach top tie bar to bracket. Tighten locknut to 30-33 ft-lbs (40.7-44.7 Nm).
 - c. Secure ignition wires to main wiring harness using a **new** cable strap.

Carburetor

1. Attach throttle cables to carburetor.
 - a. Install idle control cable into longer, inboard cable guide on carburetor.
 - b. Install throttle control cable into shorter, outboard cable guide on carburetor.

NOTE

The fit between the carburetor and the seal ring is tight. For ease of installation, lubricate the mating surfaces, carburetor body and seal ring with liquid dish soap or tire mounting lube prior to assembly.

2. See [Figure 4-12](#). Connect fuel drain hose to drain fitting. Connect vacuum hose to V.O.E.S. fitting. On California models, connect canister hose to carburetor.
3. Lubricate only the inside surface of seal ring that will be in contact with the carburetor. Also apply a light coat of lubricant to the spigot of the carburetor body. Push carburetor body into seal ring.
4. Attach fuel hose to carburetor with a **new** clamp.
5. Install enrichener cable on bracket and adjust. See [ENRICHENER CONTROL](#) on [page 4-12](#).
6. Adjust throttle cables. See [CARBURETOR](#) in Section 1.
7. Install air cleaner components. See [AIR CLEANER, INSTALLATION](#) on [page 4-19](#).
8. Install fuel tank. See [FUEL TANK, INSTALLATION](#) on [page 4-21](#).

Carburetor Drain Hose Routing

Route fuel drain hose from the carburetor drain fitting downward and forward through the space between the engine rear cylinder and the rear cylinder push rod covers (intake and exhaust), and then downward through the space between the engine crankcase and the oil pump.